

Installation Instructions

Motorized Latch Retraction

ML Option for XT and LX Models

Wiring for use with PS210 Power Supply



Overview

The ML option (Motorized Latch Retraction) allows for remote operation of the Syntégra's XT and LX door systems. With the application of a regulated 24 VDC signal from the PS210 Power Supply, the high-speed motor retracts the latches directly allowing it to be interfaced with access control and door automation systems.

The ML option is preinstalled from the factory with the wire connections terminated at the hinge-side of the door via a thru-wire hinge or other power transfer devices. The internally mounted, low current, motor is rated for intermittent and continuous duty. As long as the 24 VDC signal is applied, the latches, along with the XT model's pushbar, will remain retracted. The ML feature is a fail-secure system to comply with fire code and security requirements. When power is interrupted, the locking system defaults to a latched condition.

The PS210 Power Supply is specifically designed to meet the power and functional requirements of the ML option. Up to two ML devices, activated simultaneously, can be powered by the PS210. Using an alternate power supply is not advised and will void the Syntégra Limited Warranty. If battery backup is required, then specify the PS202B. Latch status monitoring is also available with Syntégra door systems to interface with automatic door operators. Contact the factory for details and ordering information.

Electrical Specifications

Rated Voltage: Regulated 24 VDC +/- 10%
Peak Current: 1 Amp
Hold Current: 225 mA

All products must be installed and maintained in compliance with all local and national building, life-safety, and electrical codes

Suggested Tools / Supplies Required:

- PS210 Power Supply
- Common hand tools – including small flat-blade screwdriver or potentiometer adjustment tool
- Pushbar release tool
- Multimeter
- 18ga (min.) 2-wire conductor and connectors appropriate for the installation

PS210 Installation

Refer to installation instructions provided with the PS210 for mounting details and wiring the primary inputs.

Fire Alarm Control Panel (FACP)

In fire rated openings, the ML option must be controlled by the FACP. Refer to the adjacent diagram. The 120VAC breaker must be shut off during this operation.

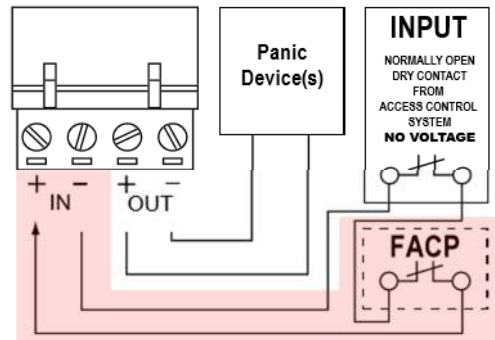

Wiring to the doors

Turn off the 120VAC circuit breaker at the panel before making these connections. The two power wires from the ML devices to the PS210 are not polarized.

With this configuration, one input switch/relay will operate up to two doors simultaneously. If the two doors need to operate independently with separate control switches, then use the PS202 (or PS202B for battery backup).

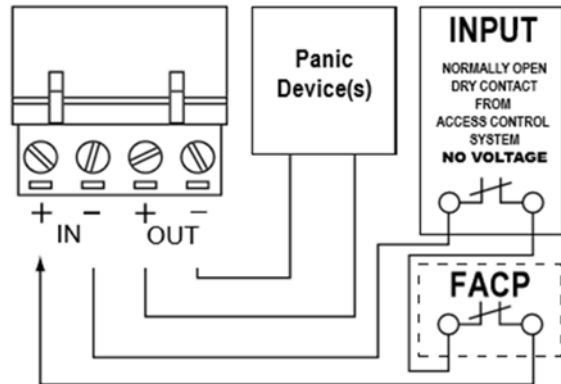

Typical wiring Diagram
For Single or Pairs of Doors

Mechanical Operational Testing

Prior to putting the ML option in service, the mechanical function of the door system must be verified as fully operational. The ML option will not correct nor overcome mechanical issues that persist from an improperly installed door. If the door does not mechanically close and latch properly, then resolve this before proceeding.

Electronic Adjustment and Diagnostics Tools

The ML option uses advanced circuitry which allows precise the adjustment of the run cycle to ensure full retraction. In addition, the ML controller offers the installer valuable diagnostic tools for troubleshooting and system verification.

Retraction Point Adjustment

The Syntégra door systems are factory adjusted prior to shipping. If updates or upgrades in hardware are performed, it might be necessary to readjust the ML option to ensure proper operation.

The motor controller resides on the back end of the motor where the two wire harnesses terminate. An adjustment potentiometer is provided to achieve the proper retraction point. A thin blade potentiometer adjustment tool (shown) or similar is required to make this adjustment. Rotating the potentiometer clockwise increases retraction and rotating the potentiometer counterclockwise decreases retraction.



Caution!

Forcing the potentiometer beyond its limits will permanently damage the control board!

Adjustment Steps

1. Use the pushbar release tool to set the outer pushbar into the 'service' position to expose the end cap mounting screws.
2. Remove latch-side end cap, and slide the pushbar off to expose the backbar assembly.
3. Activate and hold the control switch that initiates sending power to the device, and verify that the motor retracts the holds the latch(es) fully retracted without over-travel resulting in a 'bounce' condition.
4. If necessary, adjust potentiometer (see below) in small increments (5°-10°) to the point where the latch(es) fully retract without bouncing.
5. Reinstall the pushbar, and cycle the device to ensure proper operation.

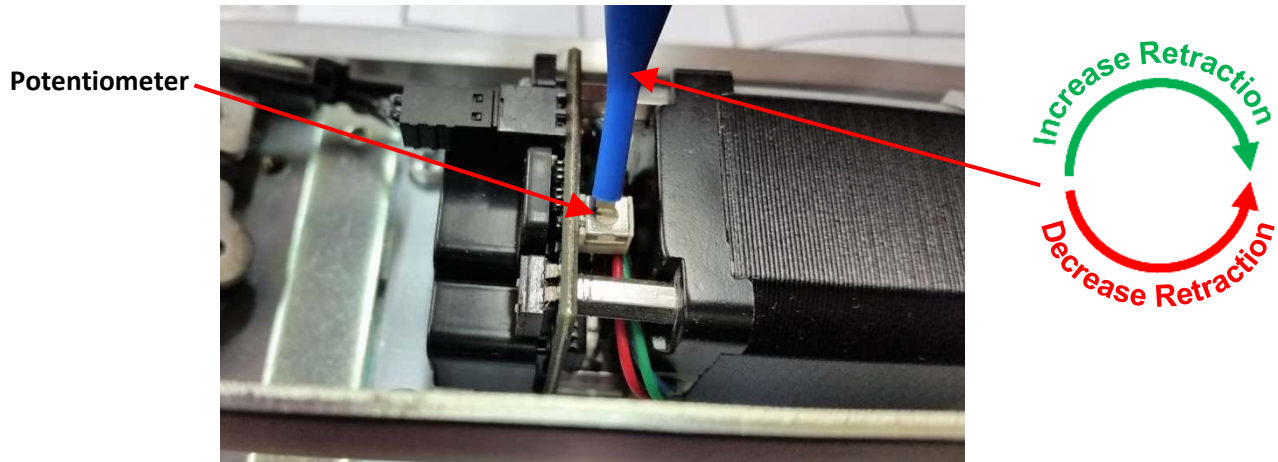

Diagnostics / Troubleshooting

The onboard controller will emit tones to help determine the status of the ML option. See below for explanation of these tones and how they can assist in ensuring proper operation of the system. Power must remain to the device for a minimum of 10 seconds to allow a complete diagnostic cycle to be completed.

Beeps	Explanation	Solution
2	Over Voltage	Measure & adjust voltage to 24 VDC +/- 10%.
3	Under Voltage	Measure & adjust voltage to 24 VDC +/- 10%.
4	Sensor Error	Verify all three sensor wires are installed correctly. Replace sensor if problem persists. Contact factory for assistance.
5	Retraction failure due to obstruction or the pushbar forced from retracted position.	<ol style="list-style-type: none"> 1. After 1st fail – 5 beeps then attempts to retract again 2. After 2nd fail – Continues 5 beep pattern with pause for 30 seconds. After 30 seconds, attempts to retract. 3. After 3rd fail – 5 beeps every 7 minutes until cleared. <p>To reset: Depress bar for 5 seconds or recycle power</p>